

Temperature sensor TJ- H

with special hygienic process connection

Temperature sensor's construction is special for using it in food industry, pharmacy companies, biotechnology and in near areas.

- Temperature range:
-50°...+180°C, -50°...+250°C.
- Cable's connection - 3-wire ceramic connection group.
- Sensors - Pt100 class B or A, Pt1000 class B (max. current 1mA) or A, thermocouples K,J.
- Transmitter could be built-in to sensor's head.

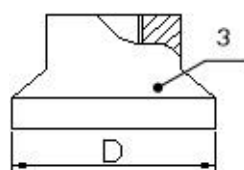
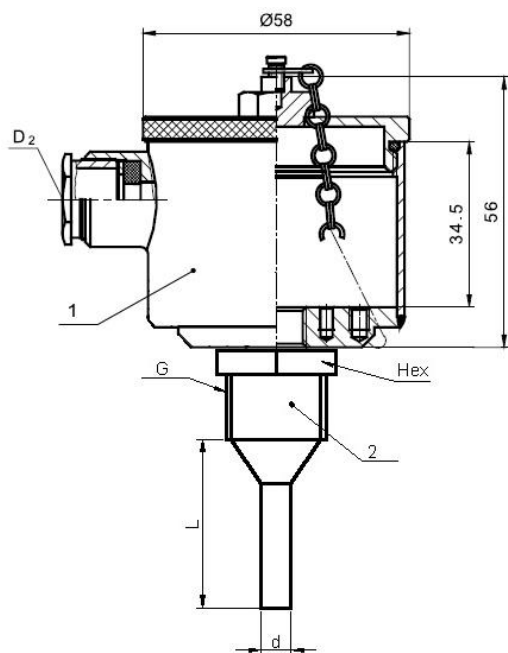

1 – cable's connection head:

MBEG – stainless steel, IP65

B or M – aluminium, IP65

2 – sensor's thermowell, stainless steel

D₂ – cable gland M16x1,5

3 – hygienic socket of process connection, stainless steel.

Thermosensor could be complete with special welded sanitary claim socket.

Models:

	I	II
Process connection G	G1/4"	G1/2"
Sensor's diameter d , mm	Ø6 mm	Ø10 mm
Sensor's length L , mm	25, 30 or on request	750, 800, 900, or on request
Key's size HEX , mm	14	22
Socket's diameter D , mm	24	30

Other ordering versions possible.



AUREGIS UAB

Savanorių pr. 271/ Mituvos g. 2, Kaunas LT-50131

Tel./fax.: +370 37 313426

Mob. : (+370) 686 38409, 614 34419, 686 54049,
698 74609, 614 71784

El. paštas: info@auregis.lt www.auregis.lt